

**“Connect & use” dish & glass washer to suit all rack sizes up to 500x500mm**



**Product Advantages:**

- **Easy-to-use** electronic controls with 2 cycles 60 & 180 seconds
- Electronic temperature gauges
- **Suits all racks up to 500x500mm** - stainless steel grid shelf supports all rack sizes
- **Re-circulating & low 2.9 litre rinse volume** machine
- **Double skin door** for strength & durability for loading machine
- Usable chamber height of 356mm
- Polypropylene wash & stainless steel rinse arm with **patented WIDE ANGLE FAN** nozzle to maximise wash & rinse performance
- **Self-cleaning cycle** on drain out
- Wash pump inlet strainer to ensure machine reliability
- **“Connect & use”**- fill & drain hoses, pump-out drain, chemical dispensers & power lead / plug included for quick & easy installation
- Adjustable rear castors and front feet for easy cleaning
- Includes 1 x plate rack & 1 x cutlery holder
- Back flow prevention device as standard to meet Watermark Approval and ATS 5200.101

**Technical Data**

flexible drain hose 1000mm	Pump-out drain standard
fresh water connection: pressure hose 1000mm	Connection size: 3/4" BSP
flow pressure	80-600kPa—rinse pump standard
incoming water temperature	55-65°C
power cord	15amp single phase plug & lead
hose for detergent	Included
hose for rinse aid	
wash tank temperature	55-60°C
rinse water temperature (booster tank)	Minimum 82°C
low temp cut-out (thermostop) activated	Yes
cycle times	60 sec. 180 sec.
water consumption	2.9litres
tank capacity	25 litres
tank heating	2.0kW
power supply	240/50/1 - 15amp
booster loading	1.8kW
total loading	2.3kW
pump capacity	370watts
loading height	356mm

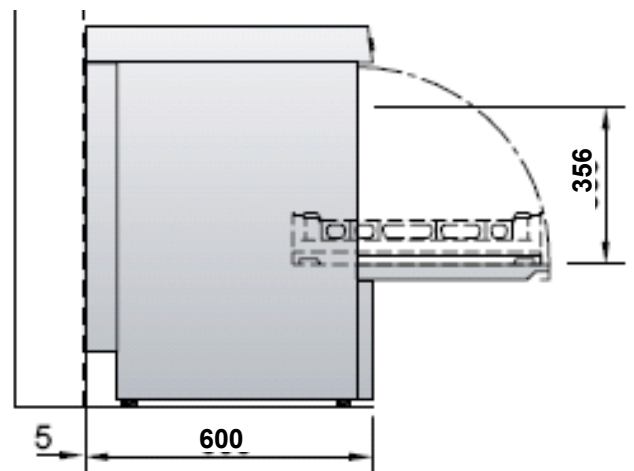
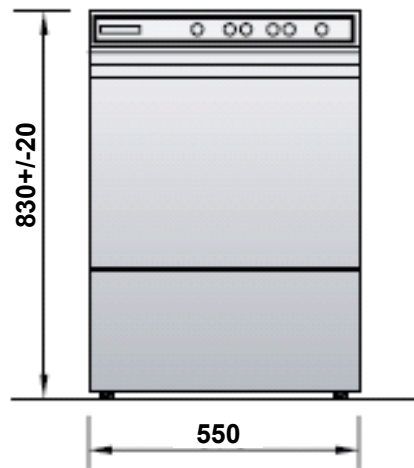

Water hardness should not exceed 3°dH, if higher we recommend using a water softener.

If mineral content is high a demineraliser may be advisable.

A		Ø 30 mm dia hose
B		Ø 3/4" s/s hose
C		240/50/1